

**Fender<sup>®</sup>**

THE SOUND THAT CREATES LEGENDS

BASS  
EXTENDED  
RANGE **BXR**  
One hundred  
**Owner's Manual**

P/N 040695

# BXR 100 Owner's Manual

Congratulations on your purchase of the Fender BXR 100 Bass amplifier. The Fender BXR 100 is the most recent effort in state-of-the-art bass amplifier technology, and is a member of the FENDER BXR series. The design of the BXR 100 was carried out with the aid of some of today's best bass players, and represents years of thought and consideration in determining features and specifications. The features included in the BXR 100 will provide a forum for almost every conceivable playing style, from "traditional" to "contemporary", and those yet to come.

The preamp section of the BXR 100 features two inputs of differing sensitivities, allowing for the use of a wide variety of input sources and levels. A MID NOTCH button is provided to enhance the mid frequency response. The 4-band EQ allows for up to 12 decibels of boost or cut in 4 bands between 80 Hz and 6KHz. The PREAMP OUT & POWER AMP IN jacks can be used as an effects loop or send and return points while slaving multiple amps together. A HEADPHONE jack automatically mutes the speaker while driving stereo headphones for private practice sessions. The quasi-balanced LINE OUT jack is used for "hum free" direct connection to recording and sound reinforcement equipment.

The rugged power amplifier is designed to give years of reliable service under all conditions. It is equipped with our exclusive DELTACOMP™ adaptive compressor system. With DELTACOMP™, it is practically impossible to clip (distort) the power amplifier. The apparent release time of the compressor is short, yet distortion at low frequencies is kept to a minimum.

The BXR 100 incorporates a highly efficient, computer-designed, turned port cabinet, and delivers a full 100 watts R.M.S. to its single fifteen inch Fender Special Design driver.

The selection of a Fender amplifier will reward you with years of quality performance and a wide range of musical sounds. This manual is designed to familiarize you with the equipment and to acquaint you with its many features. Please read it carefully so you will benefit from all the features as soon as you start using the amplifier.

The built in quality of a Fender amplifier is the result of over four decades of dedication, and the combined skills of research and development by our engineers and musicians.

That is why we proudly say **FENDER, *The Sound That Creates Legends.***

**WARNING: TO PREVENT FIRE OR SHOCK HAZARD, DO NOT EXPOSE THIS UNIT TO RAIN OR MOISTURE**

# BXR 100 Front Panel Functions

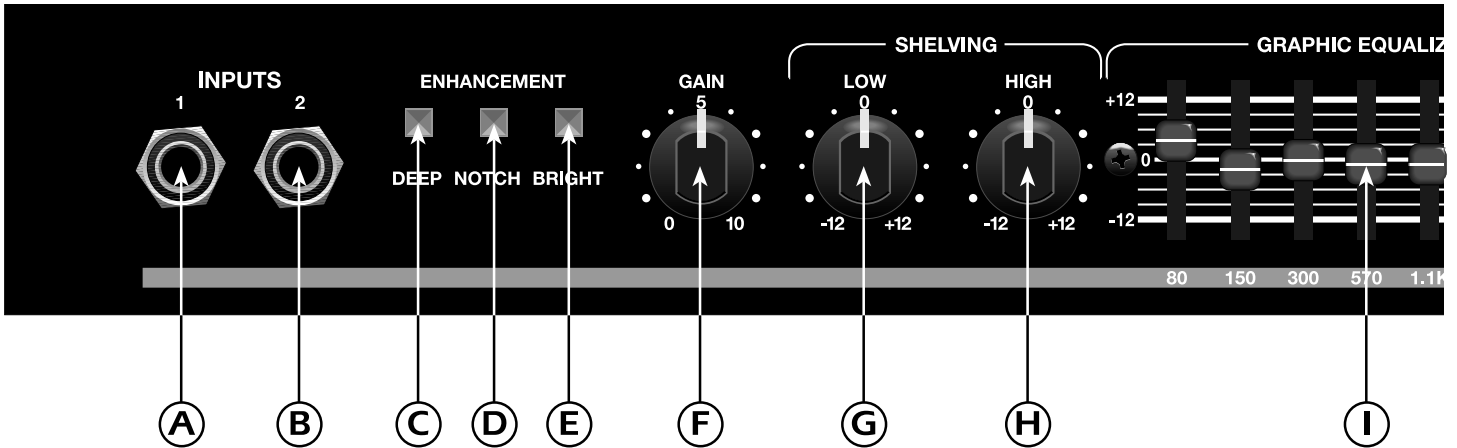

The front panel contains all items necessary for system operation and observation. Please read this section of the manual carefully to make sure you understand all the operational features for your new FENDER BXR 100 bass amplifier.

- A. INPUT 1** - A high impedance, high sensitivity plug-in connection for instruments. This input can handle as much as 2.5 volts R.M.S., and should be used with most instruments.
- B. INPUT 2** - Plug-in connection for instruments. This input is recommended for basses with active pickups, and can handle as much as 5 volts R. M. S.
- C. DEEP switch** - boosts and extends the low frequency response of the amplifier.
- D. NOTCH switch** - removes midrange, making the amp sound "punchy". This switch is good for "thump and pluck" playing.
- E. BRIGHT switch** - adds high frequency "sparkle".
- F. GAIN control** - adjusts the gain of the preamplifier. This control, in conjunction with the VOLUME control (item ), allows the use of a variety of pickups, from high-impedance

low-level acoustic pickups to high-output active pickups. Low-level pickups generally require a high GAIN setting and low VOLUME setting, while "hotter" pickups require a lower GAIN setting and a higher VOLUME setting. This maximizes headroom and minimizes noise.

- G. LOW shelving control** - adjusts the low part of the frequency spectrum, where the deep "fundamentals" reside.
- H. HIGH shelving control** - adjusts the high part of the frequency spectrum. Turning up the HIGH control will add "sparkle" to the sound.
- I. GRAPHIC EQUALIZER** - allows precise adjustment of the tonal characteristics of the amplifier. Each control provides a 12 dB boost or cut to narrow bands of frequencies centered about 80, 150, 300, 570, 1.1k, 2.1k, and 4kHz. The 80, 150, and 300 Hz controls are used to adjust the low, mid, and high fundamental notes of the bass. The 570, 1.1k, 2.1k, and 4k controls allow control of the timbre of the instrument, allowing for a very wide variety of tonal characteristics.

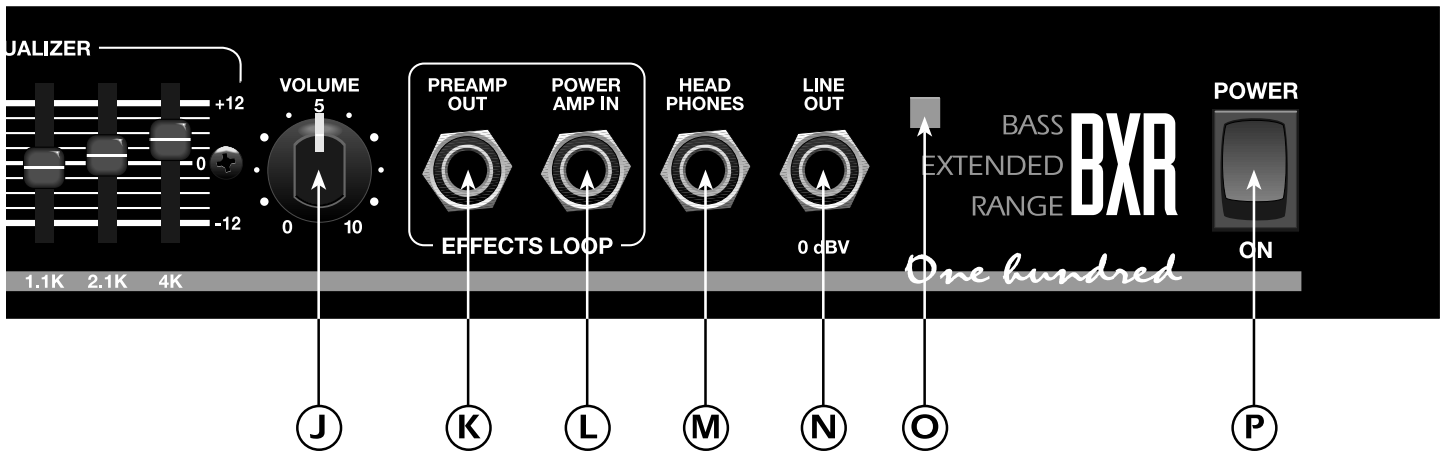

- J. **VOLUME control** - adjusts the level of the signal coming out of the pre-amplifier section. This control is used in conjunction with the GAIN control to set the overall sound level of the amplifier. In order to maximize headroom and minimize noise, instruments with low- level pickups will require a high GAIN and low VOLUME setting, while other instruments will require a lower GAIN and higher VOLUME setting. It is recommended that the VOLUME control be set as high as possible for maximum DELTACOMP™ compressor range.
- K. **PREAMP OUT jack** -This jack provides an unbalanced mono output signal from the preamp. This output can be used with the POWER AMP IN jack (item L) as a patch point for mono effects devices. It can also be used to provide a signal to a recording or sound reinforcement mixer. In addition, this output can be used to drive another BXR 100 used as a slave amp. This is done by connecting a standard guitar cord from the PREAMP OUT jack of the master amplifier to the POWER AMP IN jack (item L) of the slave.
- L. **POWER AMP IN jack** - This unbalanced input goes directly into the power amp. It automatically disconnects the preamp when used. This jack is useful when using the effects loop feature, or when using the BXR 100 as a slave amp.
- M. **HEADPHONES output jack** - This jack allows the use of stereo headphones for private listening. When this jack is used, the internal speaker is disconnected. **WARNING: BE CAREFUL WHEN USING HEADPHONES, AS EXCESSIVE VOLUME WILL RUIN YOUR HEARING!**
- N. **LINE OUT jack** - This quasi-balanced output is derived from the speaker, and is at line level, similar to that of the PREAMP OUT jack (item K). Since the LINE OUT jack is post-power amp, it provides a signal that is affected by the DELTACOMP™ adaptive compressor. The jack is wired TIP (+), RING (-), and SLEEVE ground. If the LINE OUT jack is used to connect to a balanced input, it will greatly reduce hum caused by a ground loop (a difference in ground potential) between the BXR 100 and another piece of equipment.
- O. **POWER INDICATOR** When this LED is illuminated, the BXR 100 is receiving power.
- P. **POWER SWITCH** - turns the BXR 100 ON or OFF.

# BXR 100 Rear Panel

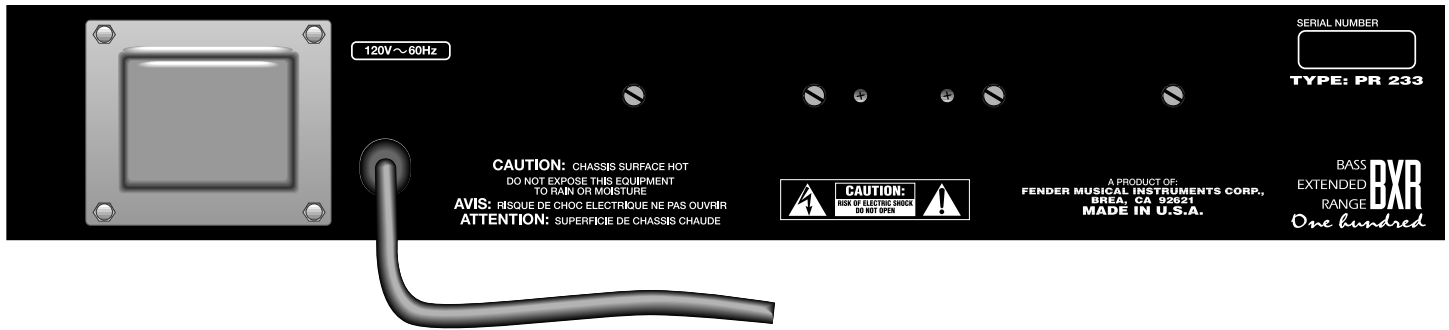

**NOTE: DO NOT BLOCK THE AIR FLOW TO THE REAR PANEL, FOR EXAMPLE, BY BACKING THE AMPLIFIER UP AGAINST A WALL.** The rear panel is used to keep the output devices from getting too hot. Should the amplifier overheat, a thermal switch will shut the amplifier off until the output devices cool.

**POWER CORD** - This amplifier is equipped with a grounding type supply cord to reduce the possibility of shock hazard. Be sure to connect it to a grounded AC receptacle. The line cord should be connected to a suitable power source, in accordance with the voltage and frequency as shown by the power rating on the rear panel. If you are not sure, check some other piece of equipment in the area. **DO NOT ALTER THE THREE PRONG PLUG.**

## COVERING CARE

The exclusive vinyl covering your cabinet has been especially designed for years of lasting beauty. A very light, soapy solution on a sponge may be used to remove dirt and residue that may accumulate in the texture. Be careful not to let any liquid come in contact with the operating surfaces. **UNPLUG THE POWER CORD BEFORE CLEANING.**

# Troubleshooters Checklist

If the amp is set up but does not function, check the following items:

- Is the amp power cord plugged into an electrical outlet?
- Is there power at the outlet?
- Are all the control knobs turned up?
- Is the volume control on the instrument turned up?
- Is the instrument properly plugged into the amplifier?  
(Eliminate any effect pedals and try another guitar cord.)

If, after checking all of the above, the system is still not performing correctly, consult your FENDER Service Dealer.

# BXR 100 Specifications

<b>Part Number:</b>	120V Version:	22-4401
	230V Version:	22-4461
<b>Type Specification:</b>	PR 233	
<b>Power Requirements:</b>	120V Version:	120VAC, 60 Hz, 2.4 A Max.
	230V Version:	230VAC, 50 Hz, 1.25 A Max.

## POWER AMPLIFIER SECTION:

<b>Power output:</b>	100 watts R.M.S.
<b>Rated load impedance:</b>	8 Ohms
<b>Distortion at 100 watts:</b>	Less than .1% @ 1kHz, below compression; less than 1% @ 1kHz, maximum compression.
<b>Sensitivity:</b>	1.03 volts R.M.S.
<b>Input impedance:</b>	22 k Ohms
<b>DELTA COMP™ range:</b>	20 db

## PREAMP SECTION:

<b>Input impedance:</b>	Input 1 - Greater than 420k Ohms (typically greater than 1 megaohm in the passband) Input 2 - 136k Ohms
<b>Sensitivity for 100 W: GAIN and VOLUME at maximum, all tone controls at "0" detent, no enhancement activated.</b>	Input 1 - 13mV Input 2 - 26mV
<b>Shelving tone controls:</b>	LOW +/- 12 dB at 60 Hz HIGH +/- 12 dB at 10kHz
<b>Graphic Equalizer:</b>	+/- 12 dB at 80, 150, 300 570, 1.1k, 2.1k, and 4kHz

## PHYSICAL SPECIFICATIONS:

<b>Height:</b>	25-1/2 inches	(64.8 cm)
<b>Width:</b>	21-1/2 inches	(54.6 cm)
<b>Depth:</b>	13-1/2 inches	(34.3 cm)
<b>Weight:</b>	64 lbs.	(29.1 kg)
<b>Speaker:</b>	15" Fender Special Design (P/N 040580)	

**WARNING: NO USER SERVICEABLE PARTS INSIDE.  
REFER SERVICING TO QUALIFIED PERSONNEL ONLY.**

# BXR 100 Block Diagram

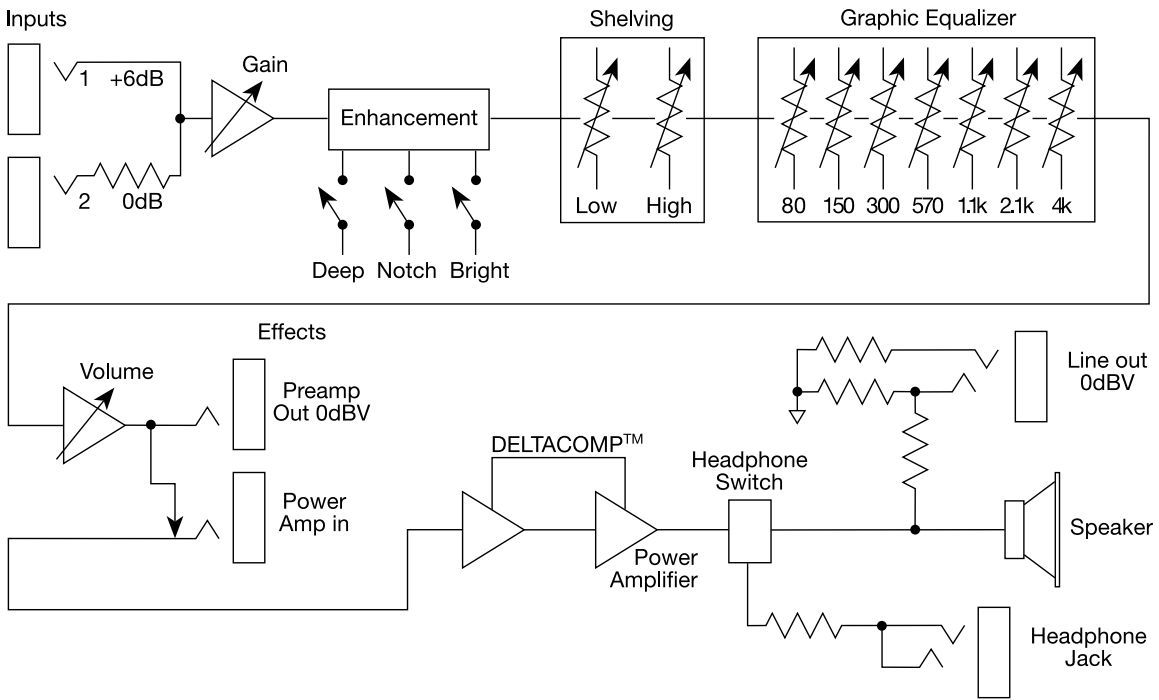

A PRODUCT OF:  
**FENDER MUSICAL INSTRUMENTS CORP.,**  
CORONA, CA 91720